

PRESSURE, VACUUM AND TEMPERATURE SWITCHES

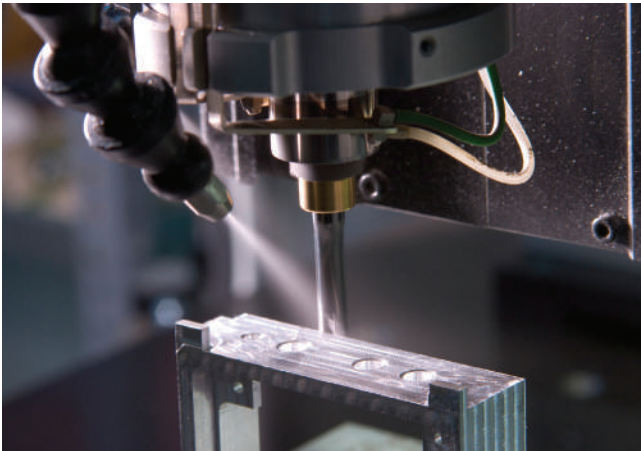

FEATURES

- Simple device in compact size
- Match application requirements with an assortment of ranges
- Increase flexibility with multiple switch outputs
- Improve accuracy with adjustable or narrow deadbands
- Easy setting via reference dial or hex screw adjustment



OVERVIEW

The 54 Series offers the OEM a combination of reliable performance and low cost. Available in pressure and temperature versions, with single or dual SPDT outputs and enclosed or open frame (skeleton) construction, the 54 Series family provides design versatility.

The 54 has been field-proven in a wide variety of OEM applications, including medical, laboratory, fire protection and heating equipment.

FEATURES

- Compact size
- Choice of one or two switch outputs
- Reference dial or hex screw-type setting
- Optional 1/2" NPT (male) by 1/8" NPT (female) polysulfone pressure connection
- Optional external manual reset
- NEMA 1 or open frame (skeleton) versions for OEM applications
- Brass bellows models

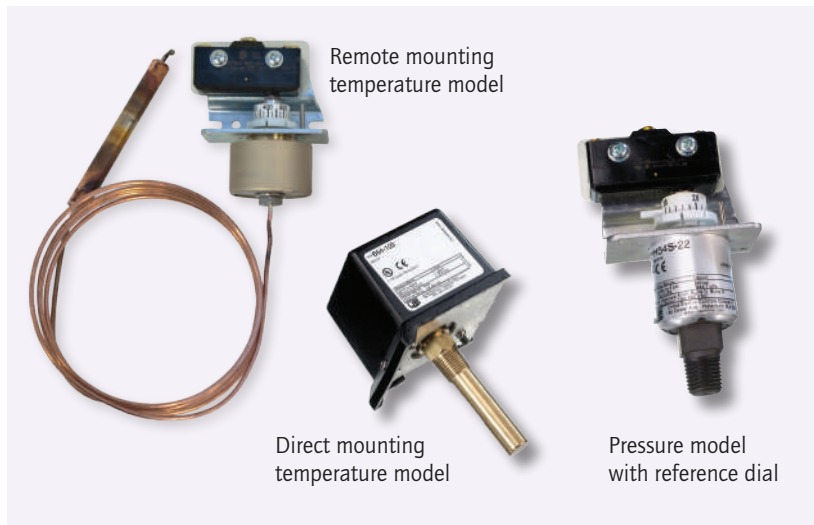

SPECIFICATIONS

AMBIENT TEMPERATURE LIMITS

Pressure Models	Models 126-164, S164B, 610-614: -40 to 160°F (-40 to 71°C); Models 22-28; 16008, 16009: 0 to 160°F (-18 to 71°C)
Temperature Models	-40 to 160°F (-40 to 71°C). Set point typically shifts less than 1% of range for a 50°F (28°C) ambient temperature change.

SHOCK

Set point repeats after 15 G, 10 millisecond duration

VIBRATION

Set point repeats after 2.5 G, 5-500 CPS

ENCLOSURE CLASSIFICATION

Types C54, C54A, B54, F54, E54, J54, J54A, H54: complies with NEMA 1 requirements.
Types C54S, B54S, F54S, E54S, J54S, J54AS, H54S: not applicable

SET POINT REPEATABILITY

Pressure Models	Models 22-28, 16008-16009, 126-164, S164B: ± 1% of full scale range; Models 610-614: ± 1.5% of full scale range
Temperature Models	± 1% of full scale range

SWITCH OUTPUT

One or two SPDT snap action switch(es); dual switch may be separated up to 100% of range; switches may be wired "normally open" or "normally closed"

ELECTRICAL RATING

15A 125/250/480 VAC resistive except models 16008-16009 - 20A 480/VAC. Electrical switches have limited DC capabilities at 24-30 VDC, 2A resistive and 1A inductive. 125 VDC, 0.5A resistive, 0.03A inductive. Consult UE for additional information.

ENCLOSURE MATERIAL

Lexan® black finish for Types J54, J54A, H54, B54, C54, C54A, E54, F54 only

WEIGHT

Approximately 12 oz.

ELECTRICAL CONNECTION

Types J54 & H54, C54, C54A, B54, E54, F54: 7/8" diameter hole; Type J54A: 1-1/16" diameter hole

PRESSURE CONNECTION

Models 22-28, 16008, 16009: 1/4" NPT (male); 126-164, 610-614: 1/4" NPT (female); S164B: 1/2" NPT (female)

TEMPERATURE ASSEMBLY

Bulb and Capillary: 6 feet copper or 304 stainless steel capillary
Immersion Stem: Brass

TEMPERATURE FILL

Non-toxic oil

TEMPERATURE DEADBAND

Typically 1% of range under laboratory conditions (70°F circulating bath at rate of 1/2°F per minute change)

APPROVALS

UNITED STATES AND CANADA



cULus
Type J54, J54A, H54
cUL Listed
Pressure: UL 508, CSA C22.2 No. 14, file # E42272
Type B54, C54, E54, F54
cUL Listed
Temperature: UL 873, CSA C22.2 No. 24, file #E10667



cURus
Type J54S, J54AS, H54S
cURus Recognized
Pressure: UL 508, CSA C22.2 No. 14, file # E42272
Type B54S, C54S, E54S, F54S
cURus Recognized
Temperature: UL 873, CSA C22.2 No. 24, file #E10667

EUROPE



Low Voltage Directive (LVD) (2006/95/EC)

UEC compliant to LVD
Products rated lower than 50 VAC and 75 VDC are outside of the scope of the LVD
The Low Voltage Directive does not apply to open frame (skeleton) models.

Pressure Equipment Directive (PED) (97/23/EC)

Compliant to PED
Products rated lower than 7.5 psi are outside the scope of the PED

Lexan® is a registered trademark of SABIC Global Technologies B.V.



54 Series

54 Series

PRESSURE MODEL CHART

Model	Adjustable Set Point Range		Deadband		Over Range Pressure ¹		Proof Pressure ²	
	psi (unless noted)	bar (unless noted)	psi (unless noted)	bar (unless noted)	psi	bar	psi	bar

J54, J54A, J54S, J54AS, H54, H54S

Buna N diaphragm and O-Ring with 1/4" NPT (male) aluminum pressure connection; limited to process temperature below 200°F.

22	30" Hg Vac to 0	-1 to 0	1 to 3.5" Hg Vac	33,9 to 118,5 mbar	0	0	50	3,4
24	3 to 30	0,2 to 2,1	0.4 to 1.5	27,6 to 89,6 mbar	50	3,4	{ 200 above set point Max 600	{ 13,8 above set point Max 41,4
25	10 to 100	0,7 to 6,9	1 to 2.5	68,9 to 172,4 mbar	{ 100 above set point	{ 6,9 above set point		
27	30 to 300	2,1 to 20,7	1.3 to 4	89,6 to 275,8 mbar				
28	50 to 500	3,4 to 34,5	1.5 to 6	103,4 to 344,7 mbar				

Brass bellows with nickel-plated brass 1/4" NPT (female) pressure connection; Model 126 has a zinc-plated steel spring exposed to media.

126	30" Hg Vac to 0	-1 to 0	0.2 to 0.9" Hg	6,8 to 30,5 mbar	3	0,2	5	0,3
137	0 to 80 "wc	0 to 199,1 mbar	1 to 8 "wc	2,5 to 19,9 mbar	3	0,2	5	0,3
144	0 to 20	0 to 1,4	0.1 to 0.5	6,9 to 34,5 mbar	20	1,4	25	1,7
146	0 to 30	0 to 2,1	0.1 to 0.6	6,9 to 41,4 mbar	30	2,1	40	2,8
152†	0 to 50	0 to 3,4	0.1 to 0.7	6,9 to 48,3 mbar	50	3,4	75	5,2
156	0 to 100	0 to 6,9	0.2 to 0.8	13,8 to 55,2 mbar	100	6,9	125	8,6
164	0 to 200	0 to 13,8	0.3 to 2	20,7 to 137,9 mbar	200	13,8	200	13,8

J54S

Welded 316L stainless steel bellows and 1/2" NPT (female) pressure connection.

S164B	4 to 200	0,3 to 13,8	0.2 to 1	13,8 to 68,9 mbar	200	13,8	200	13,8
-------	----------	-------------	----------	-------------------	-----	------	-----	------

J54, J54S

303 stainless steel piston and Buna N O-Ring with 1/4" NPT (female) pressure connection (not recommended for gas service since drying of the O-Ring can allow bleeding of the medium into the atmosphere).

610	75 to 1000	5,2 to 68,9	30 to 150	2,1 to 10,3	6000	413,7	10,000	689,5
612	125 to 3000	8,6 to 206,8	40 to 250	2,8 to 17,2	6000	413,7	10,000	689,5
614	700 to 6000	48,3 to 413,7	50 to 400	3,4 to 27,6	6000	413,7	10,000	689,5

	Adjustable Set Point Range	Adjustable Deadband	Over Range Pressure ¹	Proof Pressure ²
--	----------------------------	---------------------	----------------------------------	-----------------------------

J54S

Buna N diaphragm and O-Ring with 1/4" NPT (male) brass pressure connection; includes adjustable deadband microswitch.

16008	30 to 300	2,1 to 20,7	10 to 30	0,7 to 2,1	100 above set point	6,9 above set point	200 above set point, max 600	13,8 above set point, Max 41,4
-------	-----------	-------------	----------	------------	---------------------	---------------------	------------------------------	--------------------------------

J54

Buna N diaphragm and O-Ring with 1/4" NPT (male) brass pressure connection; includes adjustable deadband microswitch.

16009	30 to 300	2,1 to 20,7	10 to 30	0,7 to 2,1	100 above set point	6,9 above set point	200 above set point, max 600	13,8 above set point, Max 41,4
-------	-----------	-------------	----------	------------	---------------------	---------------------	------------------------------	--------------------------------

¹**Over Range Pressure:** The Maximum pressure that may be applied continuously without causing damage and maintaining set point repeatability.

²**Proof Pressure:** The maximum pressure to which a pressure sensor may be occasionally subjected, which causes no permanent damage. The unit may require calibration (e.g., start-up, testing).

† Model not available for types H54, H54S

TEMPERATURE MODEL CHART

Model	Adjustable Set Point Range		Max. Temperature		Scale ³ Division		Stem Size
	°F	°C	°F	°C	°F	°C	NPT x BT (inches)
B54, B54S, C54, C54S, C54A, C54AS , Brass immersion stem							
103	0 to 225	-17.8 to 107.2	250	121.1	10	5	3/8 x 2-1/8
109	200 to 425	93.3 to 218.3	425	218.3	10	5	3/8 x 2-1/8
							Bulb OD x Length
E54, F54 , Copper bulb and capillary							
D20BC	-130 to 120	-90 to 48.9	170	76.7	10	5	3/8 x 4-1/2
D21BC	0 to 150	-17.8 to 65.6	200	93.3	5	5	3/8 x 7
D22BC	50 to 300	10 to 148.9	350	176.7	10	5	3/8 x 4-1/2
D23BC	150 to 650	65.6 to 343.3	700	371.1	25	10	3/8 x 3-3/4
E54, F54 , Stainless steel bulb and capillary							
D20BS†	-130 to 120	-90 to 48.9	170	76.7	10	5	3/8 x 4-3/4
D21BS	0 to 150	-17.8 to 65.6	200	93.3	5	5	3/8 x 7-1/4
D22BS	50 to 300	10 to 148.9	350	176.7	10	5	3/8 x 4-3/4
D23BS	150 to 650	65.6 to 343.3	700	371.1	25	10	3/8 x 4
E54S, F54S , Copper bulb and capillary							
D21BC	0 to 150	-17.8 to 65.6	200	93.3	5	5	3/8 x 7
D22BC	50 to 300	10 to 148.9	350	176.7	10	5	3/8 x 4-1/2
D23BC	150 to 650	65.6 to 343.3	700	371.1	25	10	3/8 x 3-3/4
E54S, F54S , Stainless steel bulb and capillary							
D21BS	0 to 150	-17.8 to 65.6	200	93.3	5	5	3/8 x 7-1/4
D22BS	50 to 300	10 to 148.9	350	176.7	10	5	3/8 x 4-3/4
D23BS	150 to 650	65.6 to 343.3	700	371.1	25	10	3/8 x 4

† Not available Type F54

³Applies to Types B54, B54S, E54, E54S only



HOW TO ORDER

BUILDING A PART NUMBER

Select a **Type**

Refer to the "Type" section below.

Determine type number based on switch output, enclosure, adjustment and reference.

Select a **Model**

Refer to the "Model Charts."

Determine model based on adjustable range, deadband and proof pressure.

Select an **Option**

Refer to the "Options" section. (if applicable)

Determine option number based on switch output, optional materials or other product enhancements.

FOR MULTIPLE OPTIONS: Call United Electric Controls.

TYPE

J54:

J54A:

J54S:

J54AS:

H54:

H54S:

DESCRIPTION - PRESSURE MODELS

NEMA 1 enclosure; One SPDT output; internal hex adjustment with no reference dial

NEMA 1 enclosure; Two SPDT outputs; internal hex adjustment with no reference dial

Skeleton construction; One SPDT output; hex adjustment with no reference dial

Skeleton construction; Two SPDT outputs; hex adjustment with no reference dial

NEMA 1 enclosure; One SPDT output; internal adjustment with reference dial

Skeleton construction; One SPDT output; adjustment with reference dial

TEMPERATURE MODELS

C54:

C54A:

C54S:

C54AS:

B54:

B54S:

F54:

F54S:

E54:

E54S:

NEMA 1 enclosure; Immersion stem; one SPDT output; internal hex adjustment with no reference dial

NEMA 1 enclosure; Immersion stem; two SPDT outputs; internal hex adjustment with no reference dial

Skeleton construction; Immersion stem; one SPDT output; hex adjustment with no reference dial

Skeleton construction; Immersion stem; Two SPDT outputs; hex adjustment with no reference dial

NEMA 1 enclosure; Immersion stem; one SPDT output; internal adjustment with reference dial

Skeleton construction; Immersion stem; one SPDT output; adjustment with reference dial

NEMA 1 enclosure; Bulb and capillary; one SPDT output; internal hex adjustment with no reference dial

Skeleton construction; Bulb and capillary; one SPDT output; hex adjustment with no reference dial

NEMA 1 enclosure; Bulb and capillary; one SPDT output; internal adjustment with reference dial

Skeleton construction; Bulb and capillary; one SPDT output; adjustment with reference dial

SWITCH OPTIONS*

CODE

DESCRIPTION

0140

Gold contacts, 1A 125 VAC resistive. NOT AVAILABLE ON MODELS 16008-16009.

0500

Close deadband, 5A 125/250 VAC resistive. 3A, 28VDC, 1A, 48VDC, 0.5A, 125VDC resistive. NOT AVAILABLE ON B54, J54A, B54S, C54, C54S, C54A, C54AS, E54S, F54, F54S, AND MODELS 16008-16009.

1520

Adjustable deadband, 15A 125/250/480 VAC resistive. Adjustable wheel changes rise setting only. If adjustment of fall setting is required, use primary adjustment. NOT AVAILABLE ON TYPES J54A, J54AS, H54, H54S, PRESSURE MODELS 610-614, 16008-16009 & TEMPERATURE VERSIONS

1530

External manual reset, 15A 125/250/480 VAC resistive; 0.5A, 125VDC, 0.25A, 250VDC resistive. Reset on increasing pressure or temperature only. NOT AVAILABLE ON TYPES J54A, J54S, J54AS, H54S, B54S, C54A, C54AS, C54S, E54S, F54S OR MODELS 610-614, 16008-16009

2000

20A 125/250/480 VAC resistive. 0.5A, 125VDC, 0.25A, 250VDC resistive. NOT AVAILABLE ON MODELS 16008-16009.

* All switches have limited DC capabilities. Consult factory for details.

GENERAL OPTIONS

CODE	DESCRIPTION
M201	Factory set one switch; specify increasing or decreasing pressure or temperature and set point. NOT AVAILABLE ON TYPES J54A, J54AS, C54A, C54AS AND MODELS 16008-16009.
M202	Factory set two switches; specify increasing or decreasing pressure or temperature and set point. NOT AVAILABLE ON TYPES J54, J54S, H54, H54S, B54, B54S, C54, C54S, E54, E54S, F54, F54S
M270	Calibrated dial in Celsius. NOT AVAILABLE ON PRESSURE VERSIONS AND TYPES B54, B54S, C54, C54S, C54A, C54AS, F54, F54S
M277	Range indicated on nameplate in kPa or MPa. NOT AVAILABLE ON TEMPERATURE VERSIONS AND MODELS 16008-16009.
M278	Range indicated on nameplate in kg/cm ² . NOT AVAILABLE ON TEMPERATURE VERSIONS AND MODELS 16008-16009.
M444	Paper ID tag. NOT AVAILABLE MODELS 16008-16009.
M446	Stainless steel ID tag & wire attachment, limited to 2 lines of 25 characters each max. NOT AVAILABLE MODELS 16008-16009.
M540	Viton® construction (deadband and low end range may increase slightly. Consult factory); Wetted parts include Viton® diaphragm and O-Ring plus standard connection material. NOT AVAILABLE MODELS 126-164, S164B, 16008-16009 OR TEMPERATURE VERSIONS

PRESSURE CONNECTION OPTIONS

M501	Polysulfone pressure connection 1/2" NPT (male) x 1/8" NPT (female). NOT AVAILABLE MODELS 126-164, S164B, 610-614, 16008-16009 OR TEMPERATURE VERSIONS
------	--

OPTIONS FOR TEMPERATURE MODELS

UNION CONNECTORS

For all bulb & capillary switches

Option	Replacement Number	Description
<u>Brass</u>		
W027	SD6213-27	1/2" NPT w/ 3/4" bushing
W045	SD6213-45	3/4" NPT
W051	SD6213-51	1/2" NPT
<u>304 Stainless Steel</u>		
W028	SD6213-28	1/2" NPT w/ 3/4" bushing
W046	SD6213-46	3/4" NPT
W050	SD6213-50	1/2" NPT

THERMOWELLS

For all bulb & capillary switches

<u>Brass</u>		
W075	SD6225-75	3/4" bushing adapter, 4" BT
W191	SD6225-191	1/2" NPT, 4" BT
W118	SD6225-118	3/4" bushing adapter, 7" BT
W192	SD6225-192	1/2" NPT, 7" BT
<u>316 Stainless Steel</u>		
W076	SD6225-76	3/4" NPT, 4.5" BT
W193	SD6225-193	1/2" NPT, 4.5" BT
W119	SD6225-119	3/4" NPT, 7.5" BT
W177	SD6225-177	1/2" NPT, 7.5" BT
<i>For all Immersion stem switches</i>		
W141	SD6225-141	1/2" NPT x 1 9/16" BT, brass
W146	SD6225-146	1/2" NPT x 1 9/16" BT, 316 stainless steel

Viton® is a registered trademark of The Chemours Company FC, LLC..

DIMENSIONAL DRAWINGS

Pressure Models

Type H54, J54 and J54A Models 22 - 28, 16009

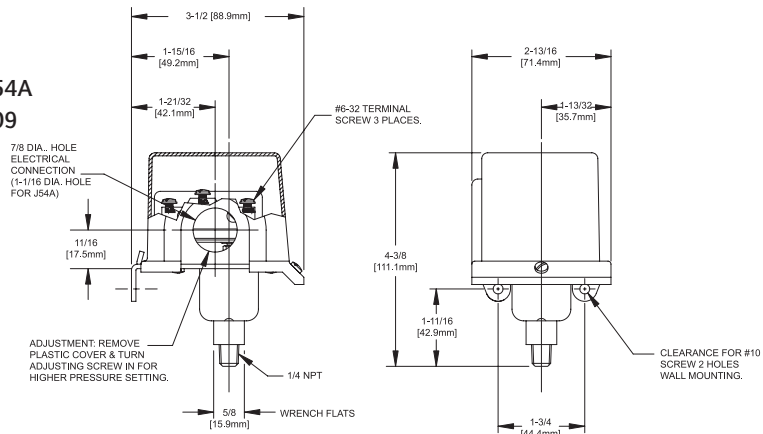

Type J54S, Models 22 - 28

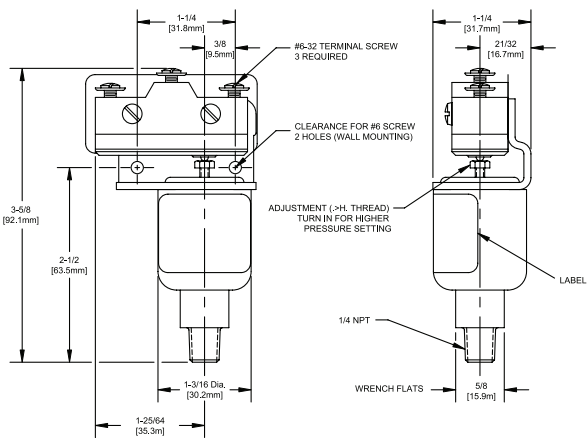

Type J54AS, Models 22 - 28

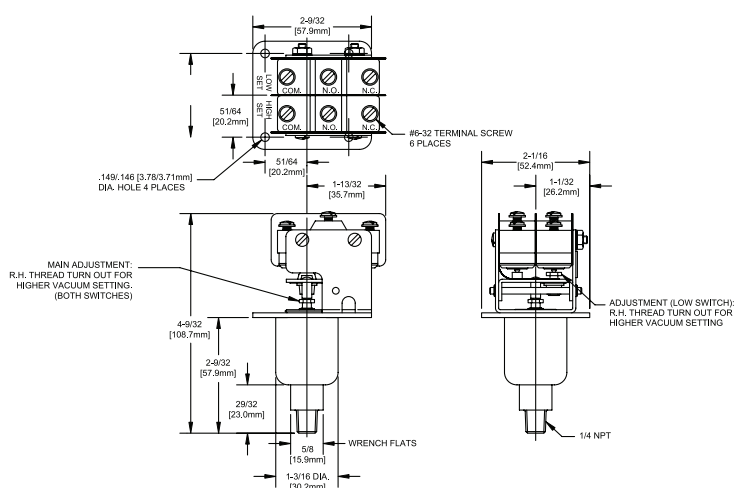

J54S, Model 16008

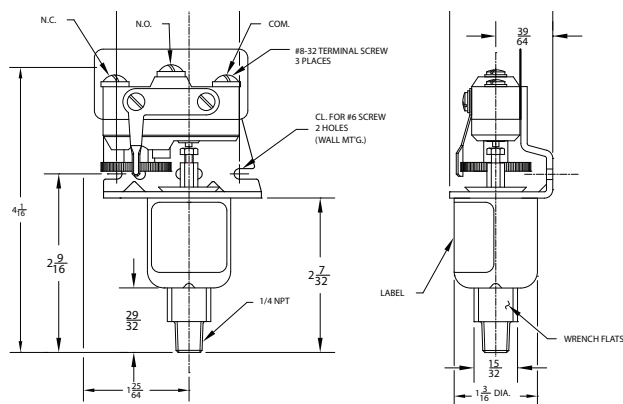

Type H54S, Models 22 - 28

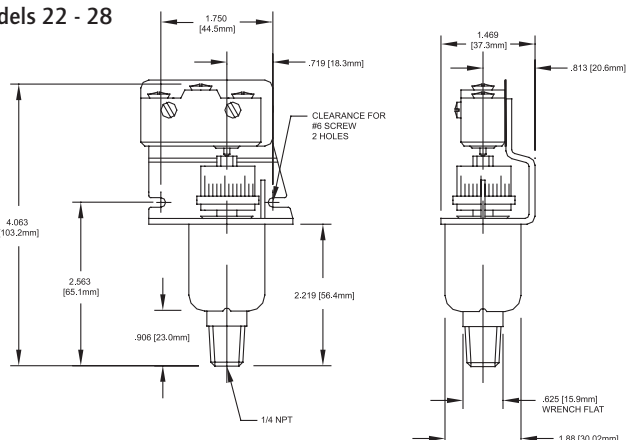

Type H54, J54, and J54A
Models 126-164

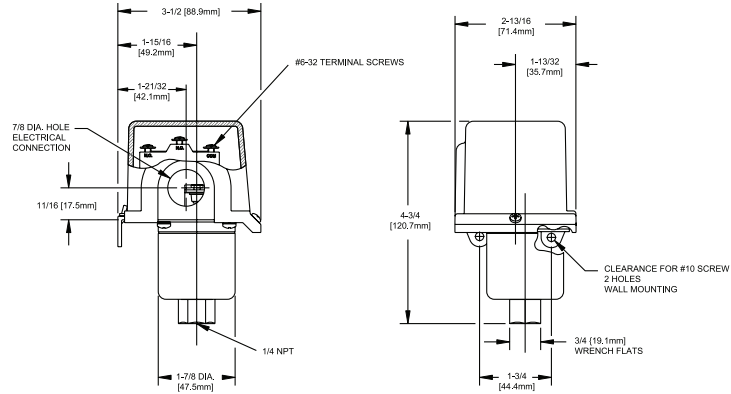

Type J54
Models 610 - 614

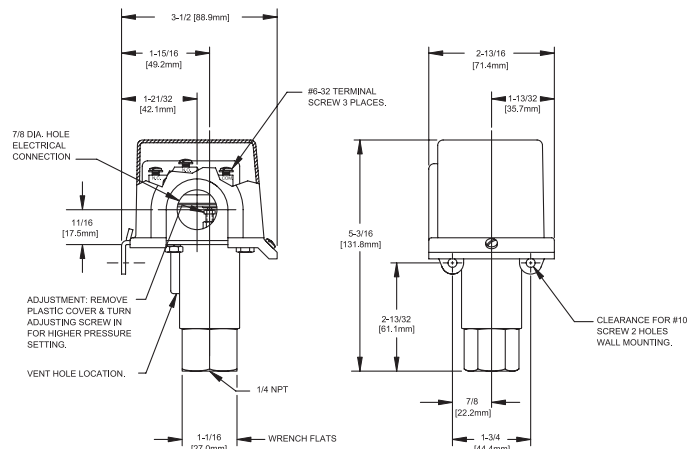

Type J54S
Models 126 - 164

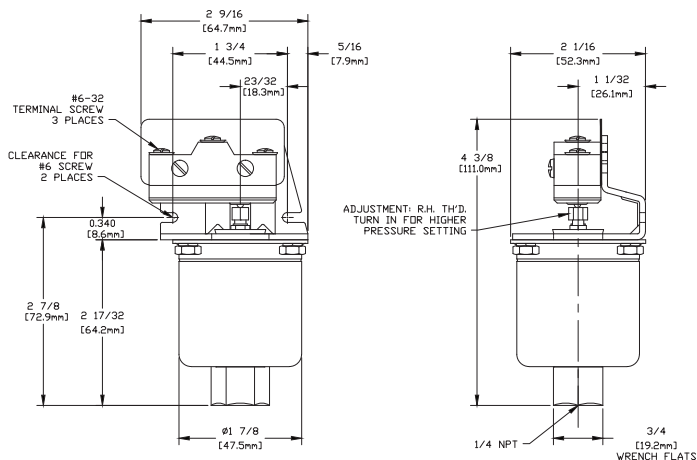

Type J54S
Models 610 - 614

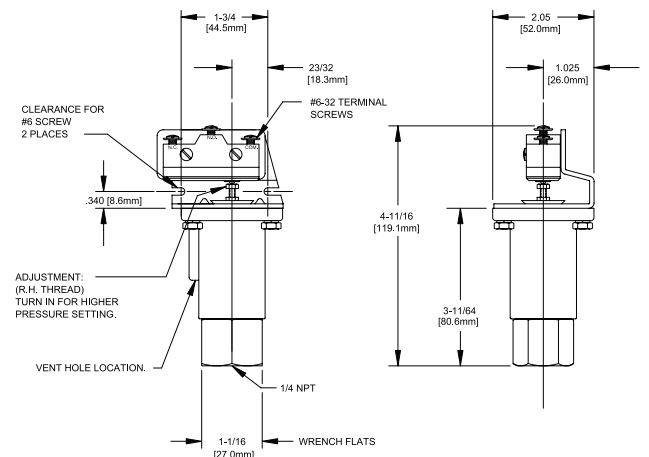

DIMENSIONAL DRAWINGS

Temperature Models

Types B54, C54

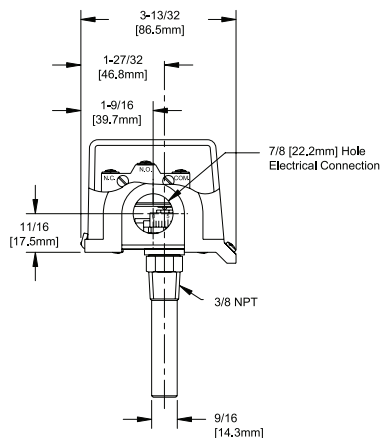

Type C54A

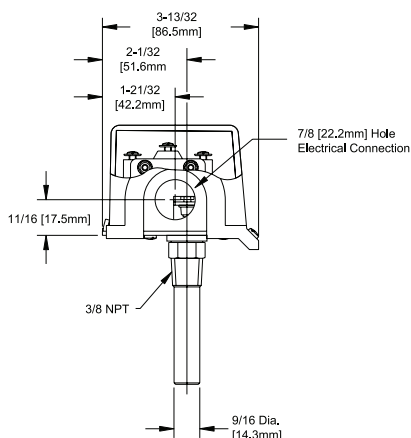

Types B54, C54, C54A

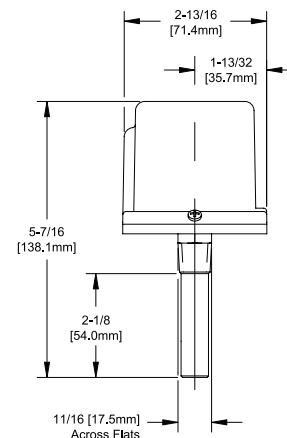

Type B54S

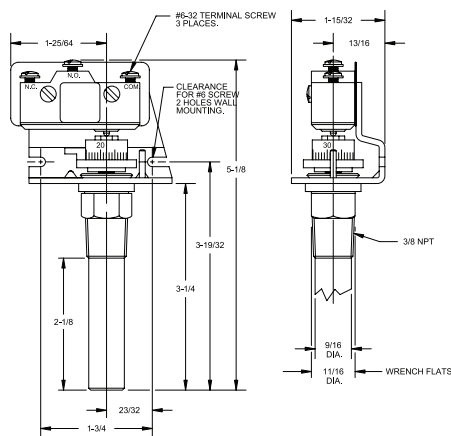

Type C54S

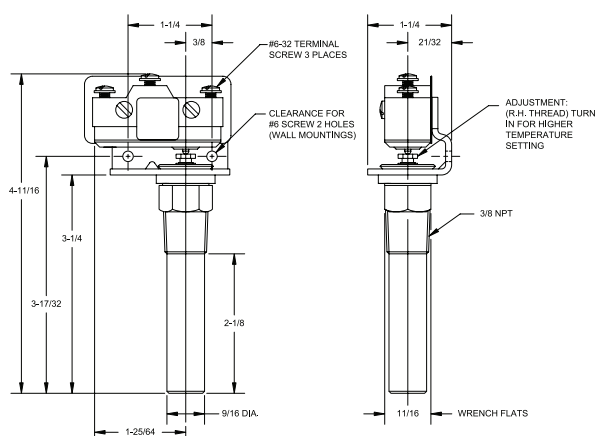

Type C54AS

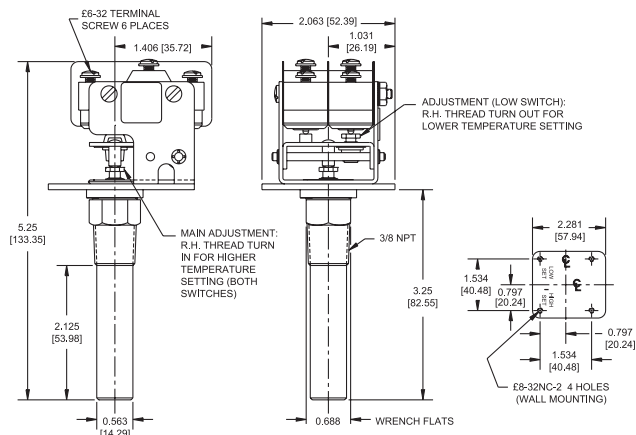

All dimensions stated in inches (millimeters)

Types E54 and F54

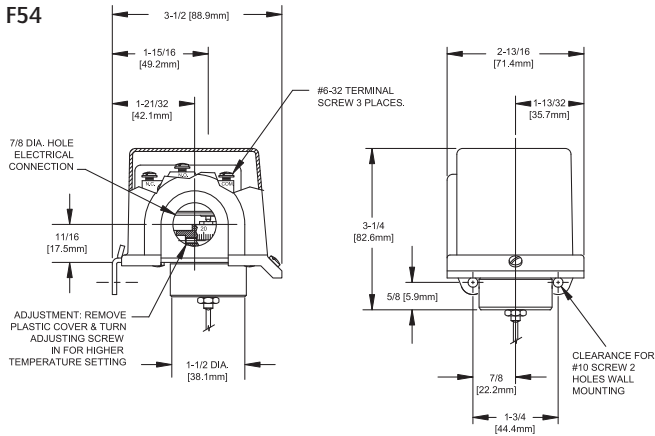

Type F54S

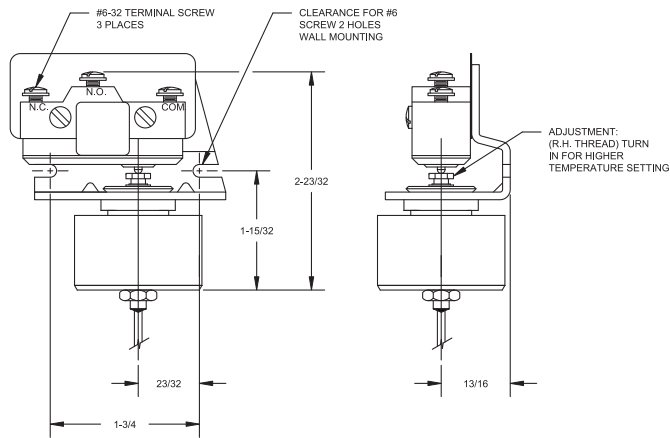

Type E54S

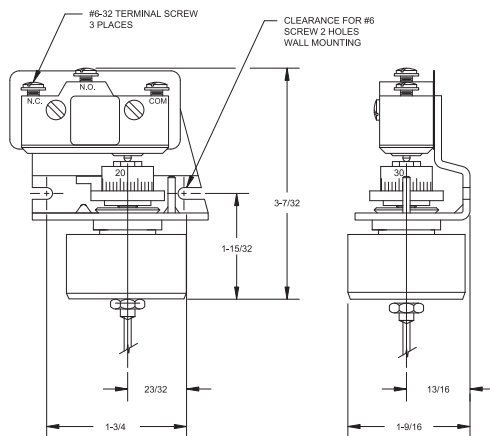

Bulb Size			
	Model	Inches	mm
Copper	D20BC, D22BC	4.50	114.3
	D21BC	7.00	177.8
	D23BC	3.75	95.3
ST/ST	D20BS, D22BS	4.75	120.7
	D21BS	7.25	184.4
	D23BS	4.00	102

RECOMMENDED PRACTICES AND WARNINGS

United Electric Controls Company recommends careful consideration of the following factors when specifying and installing UE pressure and temperature units. Before installing a unit, the Installation and Maintenance instructions provided with unit must be read and understood.

- To avoid damaging unit, proof pressure and maximum temperature limits stated in literature and on nameplates must never be exceeded, even by surges in the system. Operation of the unit up to maximum pressure or temperature is acceptable on a limited basis (e.g., start-up, testing) but continuous operation must be restricted to the designated adjustable range. Excessive cycling at maximum pressure or temperature limits could reduce sensor life.
- A back-up unit is necessary for applications where damage to a primary unit could endanger life, limb or property. A high or low limit switch is necessary for applications where a dangerous runaway condition could result.
- The adjustable range must be selected so that incorrect, inadvertent or malicious setting at any range point cannot result in an unsafe system condition.
- Install unit where shock, vibration and ambient temperature fluctuations will not damage unit or affect operation. When applicable, orient unit so that moisture does not enter the enclosure via the electrical connection. When appropriate, this entry point should be sealed to prevent moisture entry.
- Unit must not be altered or modified after shipment. Consult UE if modification is necessary.
- Monitor operation to observe warning signs of possible damage to unit, such as drift in set point or faulty display. Check unit immediately.
- Preventative maintenance and periodic testing is necessary for critical applications where damage could endanger property or personnel.
- Electrical ratings stated in literature and on nameplate must not be exceeded. Overload on a switch can cause damage, even on the first cycle. Wire unit according to local and national electrical codes, using wire size recommended in installation sheet.
- Do not mount unit in ambient temp. exceeding published limits.

LIMITED WARRANTY

Seller warrants that the product hereby purchased is, upon delivery, free from defects in material and workmanship and that any such product which is found to be defective in such workmanship or material will be repaired or replaced by Seller (Ex-works, Factory, Watertown, Massachusetts. INCOTERMS); provided, however, that this warranty applies only to equipment found to be so defective within a period of 24 months from the date of manufacture by the Seller. Seller shall not be obligated under this warranty for alleged defects which examination discloses are due to tampering, misuse, neglect, improper storage, and in any case where products are disassembled by anyone other than authorized Seller's representatives. EXCEPT FOR THE LIMITED WARRANTY OF REPAIR AND REPLACEMENT STATED ABOVE, SELLER DISCLAIMS ALL WARRANTIES WHATSOEVER WITH RESPECT TO THE PRODUCT, INCLUDING ALL IMPLIED WARRANTIES OF MERCHANTABILITY OR FITNESS FOR ANY PARTICULAR PURPOSE.

LIMITATION OF SELLER'S LIABILITY

Seller's liability to Buyer for any loss or claim, including liability incurred in connection with (i) breach of any warranty whatsoever, expressed or implied, (ii) a breach of contract, (iii) a negligent act or acts (or negligent failure to act) committed by Seller, or (iv) an act for which strict liability will be inputted to seller, is limited to the "limited warranty" of repair and/or replacement as so stated in our warranty of product. In no event shall the Seller be liable for any special, indirect, consequential or other damages of a like general nature, including, without limitation, loss of profits or production, or loss or expenses of any nature incurred by the buyer or any third party.

UE specifications subject to change without notice.

FOR A LIST OF OUR INTERNATIONAL AND DOMESTIC
REGIONAL SALES OFFICES PLEASE VISIT OUR
WEBPAGE WWW.UEONLINE.COM



**UNITED ELECTRIC
CONTROLS**

180 Dexter Avenue
Watertown, MA 02472 USA
Telephone: 617 926-1000 Fax: 617 926-2568
www.ueonline.com